

Power Control strategy of a Fuel Cell Hybrid Vehicle

Yun Haitao^a, Zhao Yulan^a, Wan Gang^b

(*a. School of Automobile and Traffic Engineering, Qingdao Technological University, Qingdao Shandong 266033, China; b. School of Automobile Engineering, Tongji University, ShangHai 201804, China*)

Abstract

Presented here is a comprehensive procedure for mathematic modeling and power control strategy design for a fuel cell hybrid vehicle (FCHV). The subsystems are modeled based on lab testing and in-field vehicle testing results from the Tongji University START3 prototype vehicle. Power control principle is designed based on the mathematic model, which uses full-states closed-loop feedback algorithm. To implement full-states feedback, a Luenberger state observer is designed to estimate open circuit voltage(OCV) of the battery. Full-states feedback controller is then designed through analyzing step-responding of the powertrain and testing data. At last of the paper, the results of simulation and field testing are illustrated. The results show that the power control strategy designed achieves the control object very well.

Keywords: fuel cell hybrid vehicle, modeling, powertrain, control

1. INTRODUCTION

In recent ten years, with the problems of energy shortage and air-pollution become more and more serious, interest in alternative automotive powertrain increases steadily. Because of its many advantages such as high efficiency, zero-emission and so on, fuel cell vehicle (FCV) is regarded as one of the most possible substitute for traditional vehicle in long-term. The main purpose of this paper is to describe the model-based development processes of the FCV power control strategy which is applied in Tongji University START3 prototype FCHV.

As the automotive engine, fuel cells have some problems such as slow responding, difficulty cold starting,

* Corresponding author. Tel: +86-532-8687-6910
E-mail addresses: yunht@163.com

and braking energy can't be recycled. So power battery is applied in FCV powertrain usually. This is so-called fuel cell hybrid vehicle(FCHV). Most major vehicle manufactures have developed prototype FCV for technology evaluation and demonstration purpose [1,2,3]. However, since these vehicles are not meant for production, they are put together swiftly. Model-based, systematic development processes that are commonly adopted for traditional (internal combustion engine powered) vehicles, are rarely explored to their full potential in the development of these prototype vehicles.

Academic research groups are also working actively on this emerging technology. Guezennec et al. [4] solved the supervisory control problem of a FCHV as a quasi-static optimization problem and found that hybridization can significantly improve the fuel economy of FCVs. Mohsen Mohammadian et al. [5] deal a control strategy developed for optimizing the energy flow by using evolutionary algorithms implemented on a fuel cell hybrid vehicle to reach the best performance, fuel economy, emission and acceptable operation of this hybrid structure. The National Renewable Energy Laboratory included a fuel cell system option in its simulation model ADVISOR [6], which can simulate FCVs and HEVs with ease.

Up to today, few papers have published detailed models of a FCHV powertrain, and model-based, systematic development processes was not used in control design for FCHV powertrain. The major feature of this study is model-based control system design for FCHV powertrain. Which is carried out by three steps: Firstly, a state-space mathematic model of the FCHV powertrain is formulated based on its equivalent circuit model and test data. Then, power control strategy is developed based on the mathematic model, which uses full-states feedback algorithm. At last, the strategy is validated by simulation and field testing.

2. STATE-SPACE MATHEMATIC MODEL OF THE POWERTRAIN

2.1 Equivalent Circuit Model of the Powertrain

The FCHV studied in this paper is Tongji University START3 prototype vehicle. The powertrain configuration of START3 is showed in Fig.1. A permanent magnet synchronization motor drives wheels through a slow-down gear-box. The electric motor inverter uses vector control strategy and the electric motor

can work in four quadrants. A DC-DC converter (DC/DC) is placed between fuel cell engine (FCE) and the motor inverter, its purpose is to compensate the over soft output characteristic of FCE, namely resistance matching. A Li-ion battery is parallel connected to main circuit, as assistant power source, its function is recycling braking energy, providing peak power, and helping with the transient part of power load.

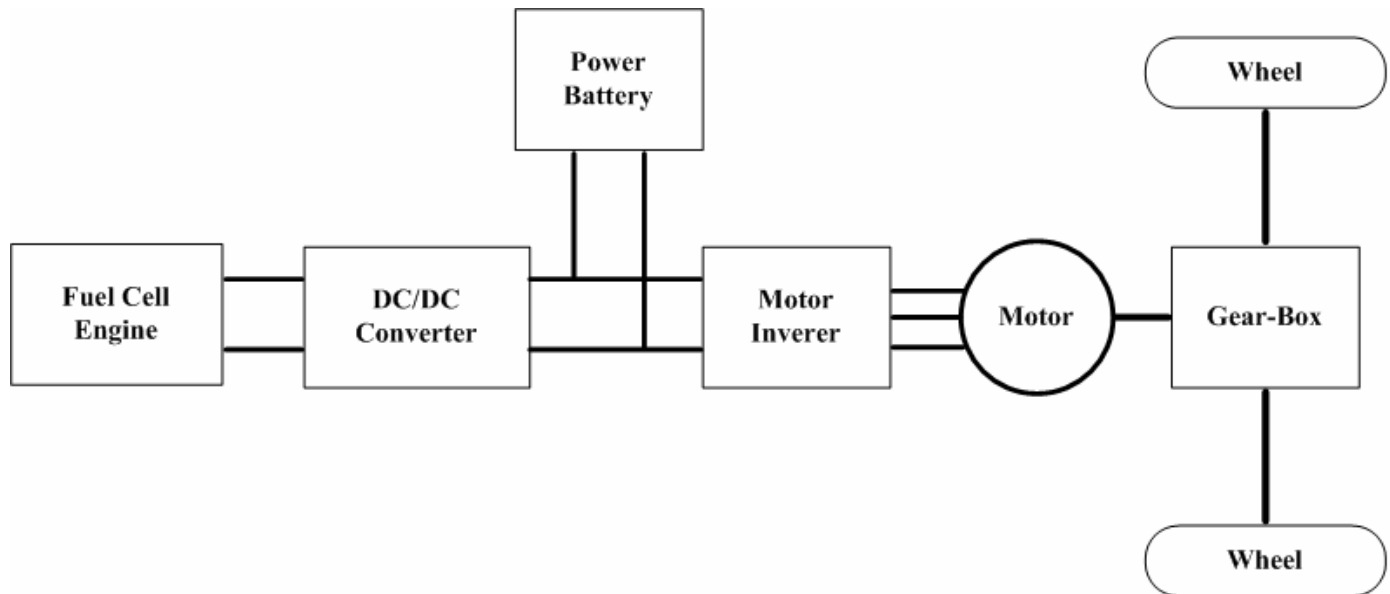

Fig.1 Schematic configuration of the START3 FCHV

In the powertrain of START3, the DC/DC is current control and the motor is torque control, so both of them can be regarded as a constant current source. Bus voltage of the main circuit is equivalent to output voltage of battery. An equivalent circuit model can be abstracted consequently, as shown in Fig.2. In this equivalent circuit model, battery is represented by a third-order equivalent circuit model which is proposed and validated in [7].

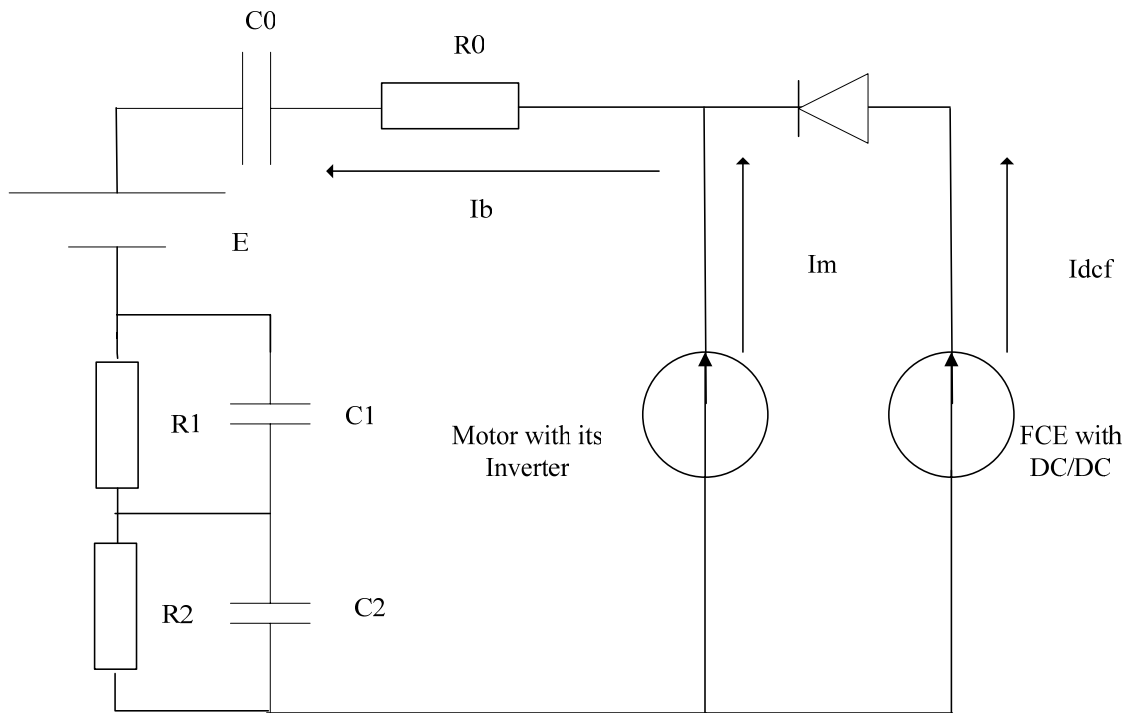

Fig.2 Equivalent circuit model of the FCHV powertrain

Where I_m : current of the motor, I_{dcf} : current of the DC/DC, I_b : current of the battery. R_0, R_1, R_2 : equivalent resistant. C_0, C_1, C_2 : equivalent capacitance. E : equivalent voltage.

2.2 Test Bench

Most components of START3 powertrain were designed specifically. They were bench-tested for factory acceptance before vehicle integration. A test bench was constructed, which enables more precise and controlled testing of individual components. In addition to subsystem function verifications, special-purpose tests were also designed to obtain the necessary data to build dynamic model and efficiency map of the subsystems.

The component configuration of test bench for fuel cell engine and electric motor is roughly same as the powertrain of START3 while an electric power load system (Supplied by Arbin) was used to simulate the power load or power source. The DC/DC and battery pack were tested using the test bench which was designed specially.

2.3 Mathematic Modeling

(1). FCE model

The fuel cell stack used in the powertrain is a medium-pressure system. Compressor rotational speed and

supply manifold pressure have time constants in the order of a few hundred milliseconds, which are significantly faster than the vehicle longitudinal dynamics. Therefore, if the purpose of the model is for supervisory-level control design, it is appropriate to ignore these state variables. However, for fuel cell breathing control at the servo-level, it would not be possible to ignore those dynamics. Another fuel cell stack dynamic variable is the stack temperature (which may have to be considered together with the stack membrane relative humidity in a highly accurate model). Again for the high-level power management control design purpose, the stack temperature is assumed to be a model parameter in the simulations and analyses. As a first step, we assume that the stack temperature is well regulated by a cooling system, and thus we will focus on the modeling and control design under this given temperature.

In the powertrain control system, the input command of FCE is power setting P_{fset} , the output is upper limit of output power P_{Lmt} . One fact should be known is that in the powertrain system, P_{Lmt} only denote the real-time output capacity of FCE, but not the real-time output power of FCE. Real-time output power of FCE is influenced by power load and battery SOC. According to [8], FCE is a nonlinear dynamic system, and in fuel cell control level FCE model must be nonlinear and very complicated. But in powertrain control level too complicated FCE model is unnecessary. In the powertrain control system, the relationship between P_{Lmt} and P_{fset} is just the FCE model. According to [8] and bench test data (Fig.3), the relationship between them can be simplified as a first-order system approximately, as the transfer function shown in Eq.(1). In Fig.3, it also can be seen that time constant of the first-order function is just little different in anterior time and posterior time. The simplification is advisable for mathematic modeling and control system design, and it will also be justified by model parameters estimation and validation later.

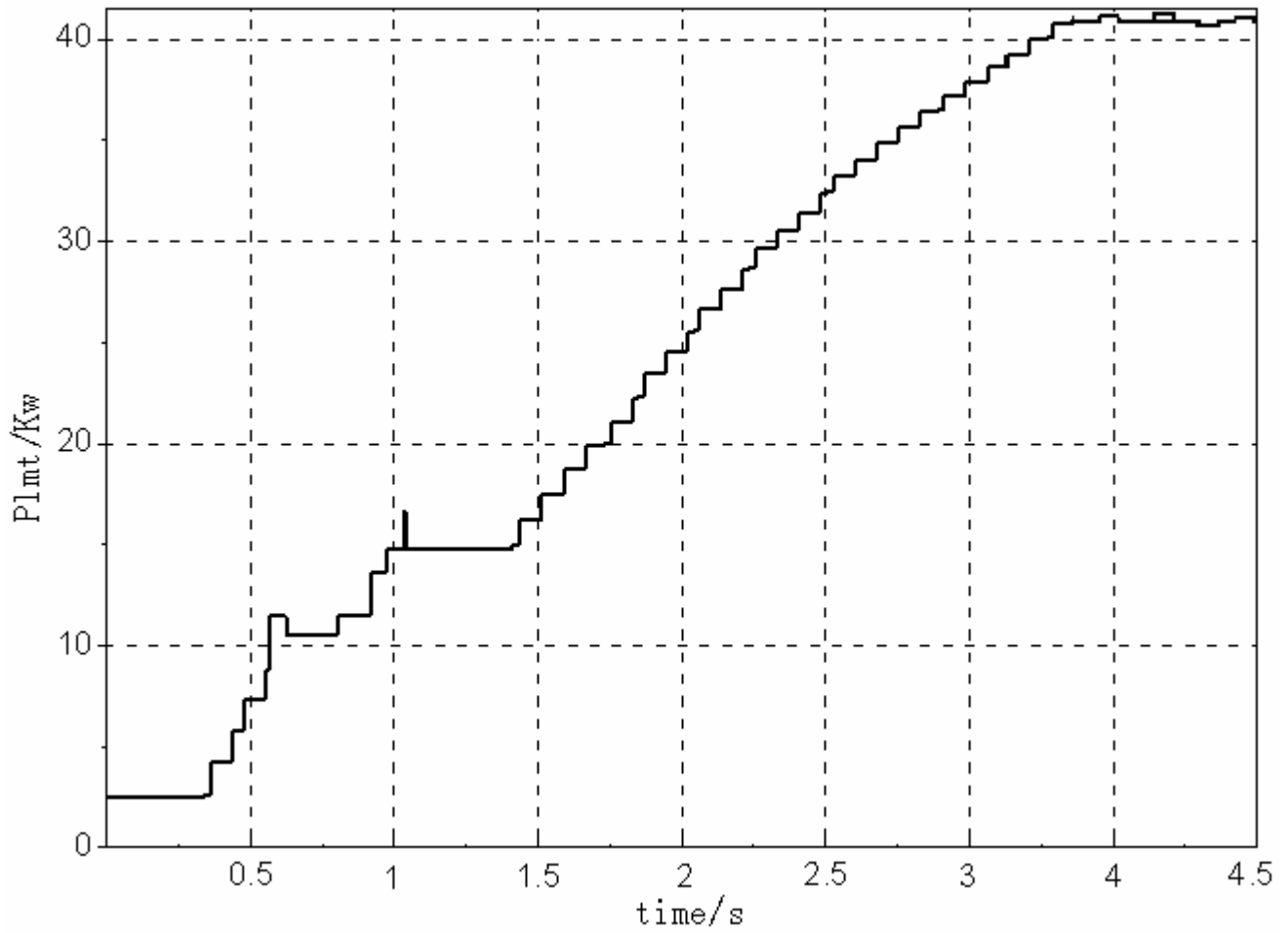

Fig.3 Relation between P_{fset} and P_{Lmt} in bench-test(Where $P_{fset}=40\text{Kw}$)

$$G_{K_{fce}}(s) = \frac{P_{Lmt}(s)}{P_{fset}(s)} = \frac{K_{fce}}{T_{fce}s + 1} \quad (1)$$

Where K_{fce} , T_{fce} : constants.

(2). DC/DC model

The input command of DC/DC is current setting I_{dcfset} , the output is actual current I_{dcf} . According to the bench test data (Fig.4), the relationship between them can be simplified as a first-order system, as the transfer function shown in (2). The simplification is advisable for mathematic modeling and control system design, and it will also be justified by model parameters estimation and validation later.

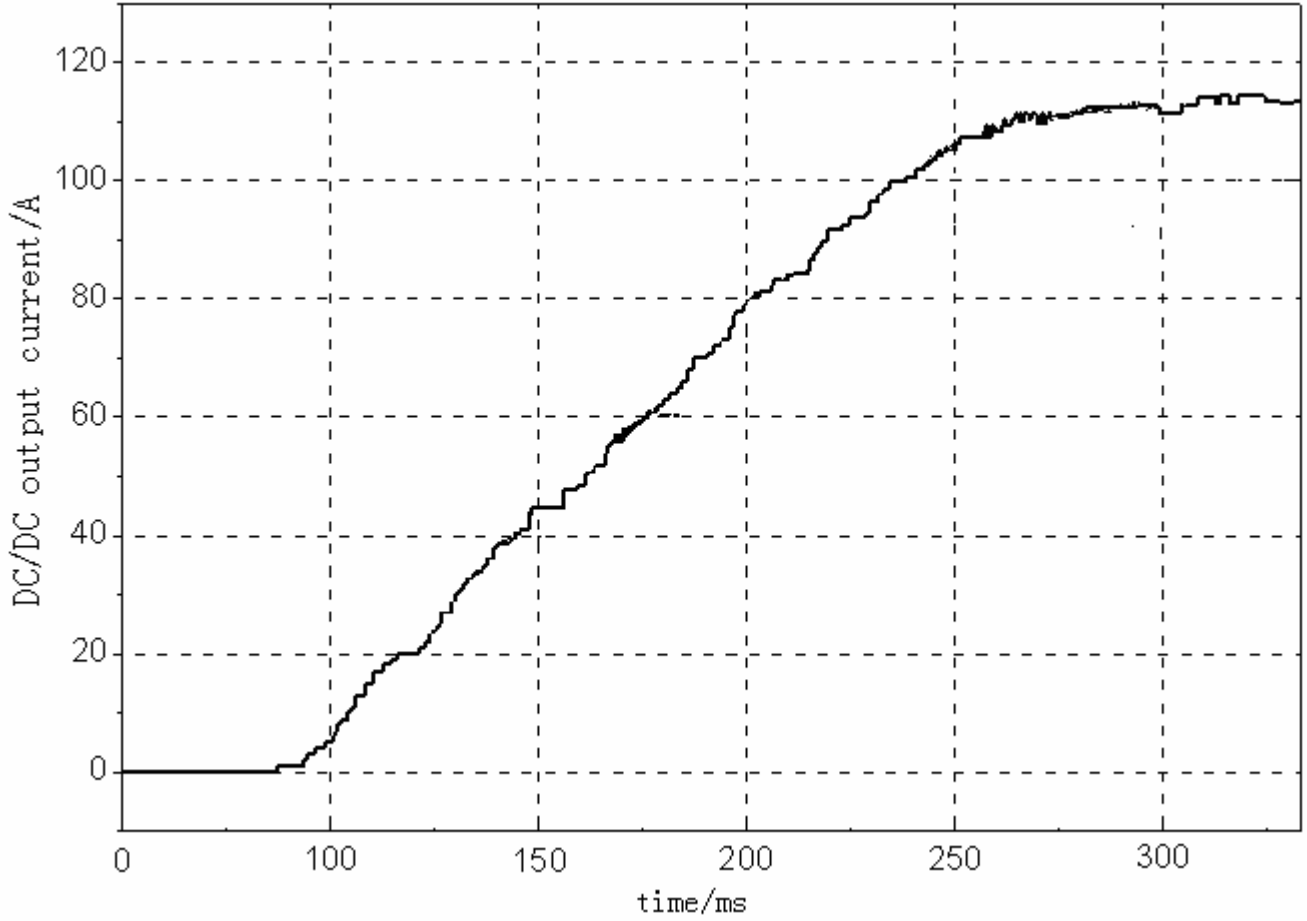

Fig.4 Relation between I_{dcfset} and I_{dcf} in bench-test(Where $I_{dcfset}=110A$)

$$G_{K_{dcf}}(s) = \frac{I_{dcf}(s)}{I_{dcfset}(s)} = \frac{K_{dcf}}{T_{dcf}s + 1} \quad (2)$$

Where K_{dcf} , T_{dcf} : constants.

In practice, response speed of the DC/DC is slowed down to protect FCE, namely I_{dcfset} is limited by P_{Lmt} . To reflect this relationship in mathematic model, I_{dcfset} is set to upper limit and the FCE and DC/DC are looked as one current source. According to Eq.(1) and Eq.(2) this current source can be denoted by transfer function, as shown in (3).

$$G_{K_f}(s) = \frac{I_{dcf}(s)}{I_{dcfset}(s)} = \left(\frac{K_{dcf}}{T_{dcf}s + 1}\right) \left(\frac{K_{fce}}{T_{fce}s + 1}\right) \quad (3)$$

Where U_{bus} : bus voltage. Because Fig.3 and Fig.4 show that responding speed of DC/DC is much fast than that of FCE (about 20:1), T_{dcf} can be omitted in simplified mathematic model. Eq.(3) can be simplified as

$$G_{Kf}(s) = \frac{I_{def}(s)}{I_{defSet}(s)} = \frac{K_{def}K_{fce}}{T_{fce}s+1} = \frac{K_f}{T_f s+1} \quad (4)$$

Where $K_f=K_{def}K_{fce}$, $T_f=T_{fce}$.

(3). Motor-driver model

The input command of electric motor inverter is torque setting Tq_{set} , the output is actual torque Tq_{Is} . Because bench-test data shows that the electric motor respond very fast, and the relationship between its output and input is linear, it can be described by a first-order system, as the transfer function shown in Eq. (5).

$$G_{Kmc}(s) = \frac{Tq_{Is}(s)}{Tq_{Set}(s)} = \frac{K_{mc}}{T_{mc}s+1} \quad (5)$$

Where K_{mc} , T_{mc} : constants. Because the electric motor current is function of its torque, Eq. (5) is modified as

$$G_{Km}(s) = \frac{I_m(s)}{I_{mset}(s)} = \frac{Tq_{Is}(s)}{Tq_{Set}(s)} = \frac{K_{mc}}{T_{mc}s+1} \quad (6)$$

(4). Battery model

As shown in Fig.2, the battery is simulated by the third-order RC circuit model which has transfer functions shown in Eq. (7).

$$\begin{cases} G_{Kb0} = \frac{U_0(s)}{I_b(s)} = -\frac{1}{C_0s} \\ G_{Kb1} = \frac{U_1(s)}{I_b(s)} = -\frac{R_1}{R_1C_1s+1} \\ G_{Kb2} = \frac{U_2(s)}{I_b(s)} = -\frac{R_2}{R_2C_2s+1} \end{cases} \quad (7)$$

Where I_b : battery current, U_0 , U_1 , U_2 : voltages across C0、C1、C2. According to [3], U_0 is equivalent to open circuit voltage (OCV) of the battery.

Uniting the Eq.(4),(6),(7) and taking inverse Laplace transform, a state-space model of the powertrain emerge as shown in Eq.(8).

$$\begin{cases} \dot{x} = Ax + Bu \\ y = Cx + Du \end{cases} \quad (8)$$

Where state vector $\mathbf{x}=[I_{dcf} I_m U_0 U_1 U_2]^T$, input vector $\mathbf{u}=[P_{fset} I_{dcfset} I_{mset}]^T$, output vector $\mathbf{y}=[I_{dcf} I_m U_{bus} P_{lmt}]^T$.

A, B, C, D are state matrix which are defined in Eq.(9).

$$A = \begin{bmatrix} -\frac{1}{T_f} & 0 & 0 & 0 & 0 \\ 0 & -\frac{1}{T_{mc}} & 0 & 0 & 0 \\ \frac{1}{C_0} & -\frac{1}{C_0} & 0 & 0 & 0 \\ \frac{1}{C_1} & -\frac{1}{C_1} & 0 & -\frac{1}{R_1 C_1} & 0 \\ \frac{1}{C_2} & \frac{1}{C_2} & 0 & 0 & -\frac{1}{R_2 C_2} \end{bmatrix}, B = \begin{bmatrix} 0 & \frac{K_f}{T_f} & 0 \\ 0 & 0 & \frac{K_{mc}}{T_{mc}} \\ 0 & 0 & 0 \\ 0 & 0 & 0 \\ 0 & 0 & 0 \end{bmatrix} \quad (9)$$

$$C = [R_0 \quad -R_0 \quad 1 \quad 1 \quad 1], D = [0 \quad 0]$$

2.4 Model Parameters Estimation

There are several unknown parameters in the mathematic model developed above. To estimate these parameters, the Quadratic Least Squares parameter estimation method is utilized in this paper. It is a method for linear regression that determines the values of unknown quantities in a statistical model by minimizing the sum of the squared residuals (expounded in [9] and [10]). Sample data came from the bench-test. To evaluate precision of the estimation, a variable called average-error-rate is defined in Eq.(10).

$$Ee = E(e) = \frac{1}{L} \left(\sum_{k=1}^L \left| \frac{z(k) - h^T(k) \hat{\theta}_{LS}}{z(k) - z_{base}} \right| \right) \quad (10)$$

Where L : quantity of the sample data, z_{base} is reference value of output in simulation, $h(k)$ is state vector in simulation, $\hat{\theta}_{LS}$ are estimated value of the parameters.

2.4.1 Sample Data

According to reference [9], Sample data is very important for parameters estimation. To make estimation result more adapted to real cycle, in bench-test input command (namely input excitation signals) are designed elaborately to simulate real cycle condition. Four kinds of cycle, including UDDS, ECE-EUDC, J1015 and FAST, are used in bench-test. Fig.5 shows related data in UDDS cycle.

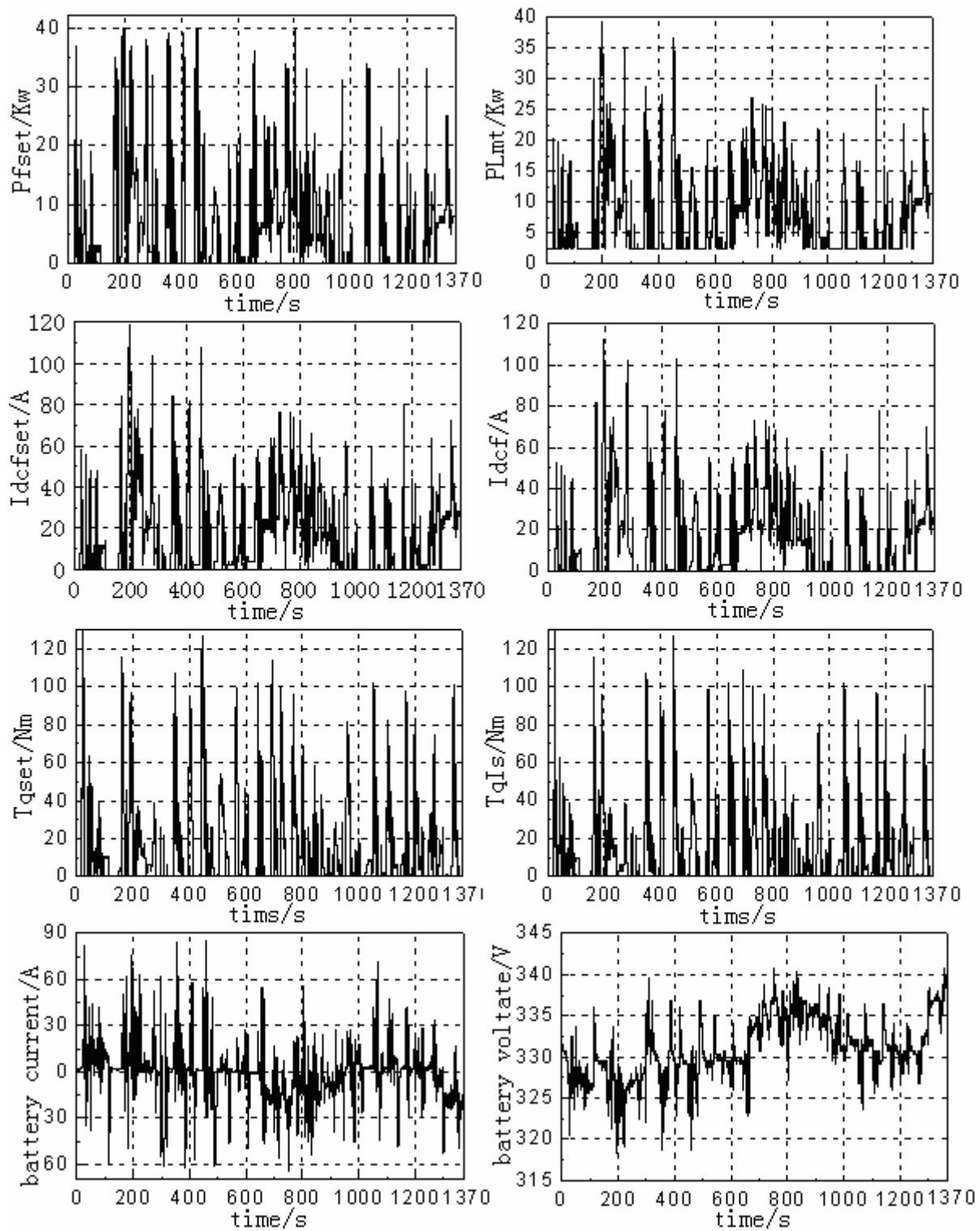

Fig.5 Sample data for parameter estimation in UDDS cycle

2.4.2 Parameters Estimation Result

In this work, the parameters are estimated based on the quadratic least squares analysis by using Matlab. The estimation results are showed in Table 1. To show the estimation precision clearly, comparison between subsystem model simulation result and test data is showed in Fig.6.

Table.1 model parameters estimation result

	FAST	UDDS	EC_EUDC	J1015	mean	E_e
K_{fce}	0.9943	1.0172	0.9981	1.0227	1.008	9.19%
T_{fce}	0.9957	1.0831	0.9214	1.1747	1.0437	
K_{dcf}	0.9723	0.9566	0.9566	0.9592	0.9612	3.85%
T_{dcf}	0.3162	0.3386	0.303	0.3091	0.3167	
K_{mc}	0.9697	0.9852	0.9814	0.9863	0.9806	3.37%
T_{mc}	0.0703	0.1015	0.0962	0.0684	0.0841	
C_0	896.94	962.87	1001.87	709.88	892.89	5.8%
R_0	0.0993	0.1058	0.1067	0.0909	0.1007	
C_1	6.3006	6.4876	9.4997	5.1079	6.8490	
R_1	0.0743	0.074	0.0601	0.0385	0.0617	
C_2	115.63	127.92	95.191	154.26	123.25	
R_2	0.1771	0.1683	0.1777	0.1134	0.1591	

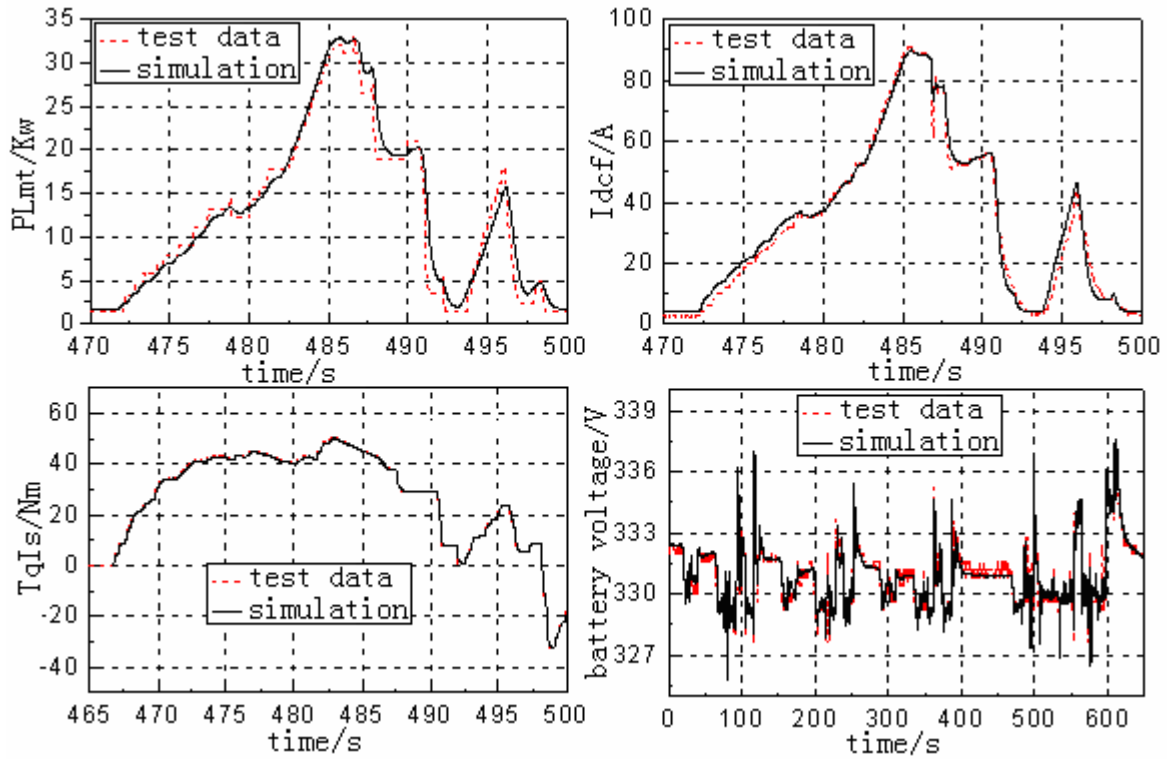

Fig.6 Comparison between subsystem model simulation and test data

A FCHV powertrain simulation model is constructed based on the mathematic model in Matlab/simulink. Even though each subsystem is modeled and validated separately, the state-space model needs to be checked to confirm that the overall model works properly. The validation is done by comparing simulation result with actual test data. The motor torque demand in bench-test is given to the simulation model as the input.

To evaluate precision of the simulation, a variable is defined in Eq.(11), which is similar to the variable defined in Eq.(10).

$$Ee' = \frac{1}{L} \left(\sum_{k=1}^L \left| \frac{z(k) - z_{sim}(k)}{z(k) - z_{base}} \right| \right) \quad (11)$$

In Eq.(11), $Z_{sim}(k)$ is simulation result.

The simulation precision is showed in Table 2. Fig.7 is comparison example between simulation result and actual test data. The validation results confirm that the powertrain simulation model is reasonably accurate and the state-space mathematic model is suitable for math-based control system development.

Table.2 Model simulation precision (Ee') in different cycle

	FAST	UDDS	EC_EUDC	J1015	meann
I_m	3.91%%	2.97%	3.15%	3.31%%	3.34%%
I_{dcf}	4.61%	4.32%	3.98%	4.13%	4.26%
I_b	6.31%	6.11%	4.73%	5.58%	5.68%
U_{bus}	7.74%	6.63%	5.12%	6.13%	6.41%

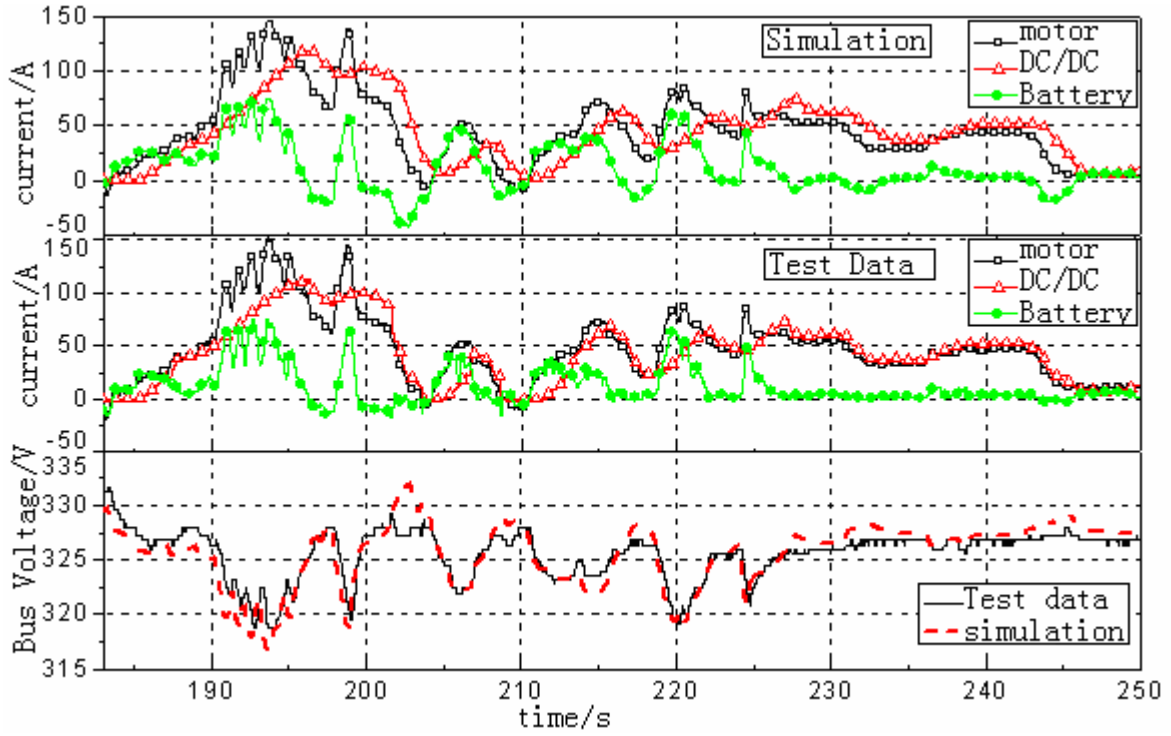

Fig.7 Comparison example between powertrain model simulation and test data in UDDS cycle

3. POWER CONTROL STRATEGY DEVELOPMENT

Based on the state-space mathematic model shown in Eq.(9) and parameters estimation results shown in Table 1, system transfer function and pole points can be figured out, as shown below:

$$W(s) = C(sI - A)^{-1}B = \begin{bmatrix} \frac{0.126 (s+0.8819) (s+0.1061) (s+0.005547)}{s (s+0.0534) (s+0.73) (s+1.25)} \\ -0.0099181 (s+0.8819) (s+0.1061) (s+0.005547) \\ \frac{}{s (s+0.0534) (s+0.73) (s+33.33)} \end{bmatrix}^T \quad (12)$$

$$\therefore s_1 = 0, s_2 = -0.73, s_3 = -0.0534, s_4 = -1.25, s_5 = -33.33$$

In Eq.(12) it can be seen that there is one pole point equals zero. According to Lyapunov's stability theory [10], it can be concluded that the powertrain is an unstable system. The principal task of the control system is to make the system stable. This is so-called power balance control in practice. The power control strategy must control the battery SOC by influence its charge/discharge current actively, otherwise the SOC of the battery may be over upper limit or lower limit. This may cause the vehicle anchor on the road.

Several academic research groups are also working actively on this energy management technology. Yuan Zhu et al.[11] solved the power control problem of Hybrid Electric Vehicles (HEV) by fuzzy-based and neural network based algorithm. This method has good robustness and adaptability, but it needs much more real-time operation and its parameters setting is very difficulty. Zaimin Zhong et al.[12] proposed a battery current and SOC double close-loop feedback algorithm to solve the power balance control problem of FCHV. In this algorithm, the power demand of electric motor was fed forward as disturbance signal, and the control parameters are set and adjusted in vehicle test. Though power balance control is effective in most cycle, this method can be improved in two respects at least. Firstly, Only the power demand of electric motor was fed back, others states of system, such as current of DC/DC, battery voltage, and so on, were not used in control system. Therefore it has potential to optimize the control strategy. Secondly, because the algorithm was based on the SOC of battery which was estimated by integral of battery current, the control system was easy to be affected by the estimated error which was usually caused by integral initial error and integral cumulated error.

Based on the research results of [11] and [12], the paper proposed a power balance control strategy which uses full-states feedback algorithm. Fig.8 shows its framework. Where x_m : control balance position, u_{ff} : feedforward command, u_{fd} : feedback command, \hat{x} : states estimated by observer or estimator. These variables have relationship shown in Eq.(13).

$$\begin{cases} u = [P_{fset} & I_{dcfset} & I_{mset}]^T = u_{ff} + u_{fd} \\ u_{ff} = [P_{fset_ff} & I_{dcfset_ff} & I_{mset_ff}]^T = [0 & 0 & I_{mset_ff}]^T \\ u_{fd} = \begin{bmatrix} P_{fset_fd} \\ I_{dcfset_fd} \\ I_{mset_fd} \end{bmatrix} = K(x_m - \hat{x}) = K \begin{pmatrix} 0 \\ 0 \\ OCV_{obj} \\ 0 \\ 0 \end{pmatrix} - \hat{x} \end{cases} \quad (13)$$

Where OCV_{obj} : expect position of the battery OCV, K : states feedback matrix.

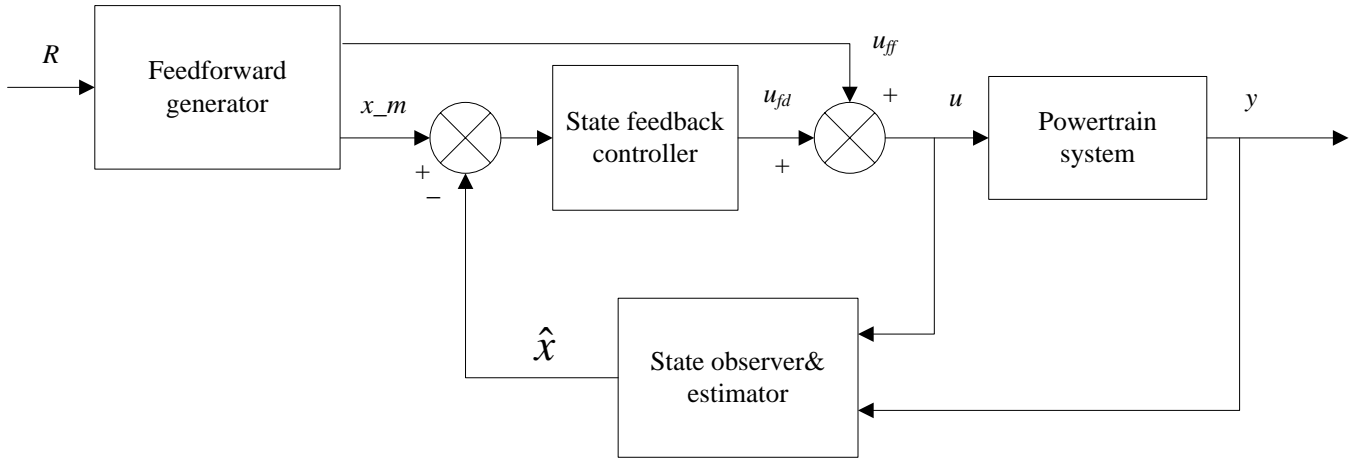

Fig.8 Framework of the power balance control strategy

3.1 Feedforward Generator

Feedforward generator figures out the feedforward command u_{ff} and the states balance position x_m . In practice, u_{ff} is figured out according to purpose of the driver basically and modified by some protection strategy, such as battery over discharge/charge protection strategy, FCE failure protection strategy, and so on. One of the state balance positions is expected OCV of battery. Because SOC and OCV have corresponding relationship in work range of the battery^[7], the battery SOC can be controlled by adjusting the state balance position.

3.2 States Observer

Because battery OCV and SOC have corresponding relationship in work range, the battery SOC can be controlled by feeding back battery OCV. In the state-space model, the state U_0 denotes OCV of the battery. It can be seen that the state U_0 is very important for control system. Unfortunately the state U_0 , namely battery OCV, can't be measured when powertrain is running. To solve this problem, a Luenberger state observer is designed based on the state-space model in this paper. Its state equation is showed in (14).

$$\dot{\hat{x}} = A\hat{x} + Bu + G(y - \hat{y}) = (A - GC)\hat{x} + Gy + (B - D)u \quad (14)$$

According to [10], no matter initial estimation error equal zero or not, as long as eigenvalue of matrix $A - GC$ has negative real part, Eq.(15) is always right.

$$\lim_{t \rightarrow \infty} [x - \hat{x}] = 0 \quad (15)$$

Eq.(15) shows that if the feedback matrix of the observer is designed properly, the battery OCV estimated by the state observer can tend to actual battery OCV by proper speed and precision. Of course the speed and precision is inconsistent while feedback matrix of the observer is designing. Because it is independent of physical realization and the feedback matrix of the observer can be designed totally free, a most reasonable feedback matrix of the observer always can be designed finally. Fig.9 is comparison between the battery OCV calculated by integral and that of estimated by the observer in a J1015 cycle vehicle test. According to [7], during short time range, the battery OCV calculated by integral equals to the actual value approximately. It can be seen from Fig.9 that the OCV estimated by observer tend to actual battery OCV by moderate speed and precision. It shows that the feedback matrix of the observer designed is reasonable.

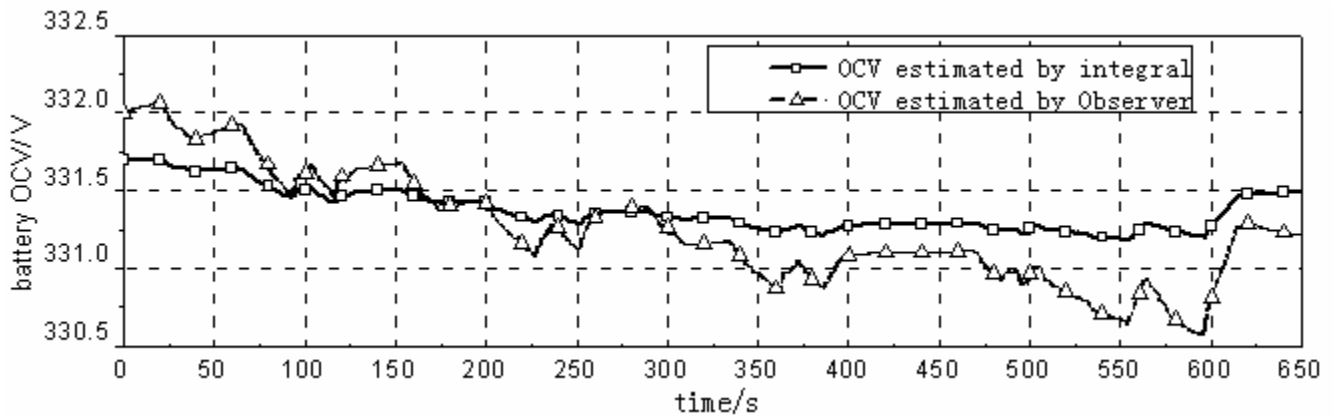

Fig.9 Battery OCV estimated by the observer and integral

3.3 States Feedback Controller

The key of states feedback controller is the states feedback matrix, as shown in Eq.(13). The states feedback matrix is a three rows and five columns matrix, and each element of the matrix has special signification which is showed in Table.3. Where, K_{ij} is element of the states feedback matrix.

Table.3 Signification of the state feedback

feedback	Signification
$K_{11}(I_{def}-I_m)$	Compensating delay of I_{def} caused by FCE slow
$K_{21}(I_{def}-I_m)$	responding feature
I_m	Making FCE power set following load power demand
$K_{13}U_0, K_{23}U_0$	Control SOC of the battery

$K_{14}U_1, K_{24}U_1$ Compensating the slow part of the battery voltage

$K_{15}U_2, K_{25}U_2$ Compensating the slow part of the battery voltage

The states feedback matrix can be designed without any constraint in control theory, but in practice, it needs to be constrained by actual conditions which are showed in Eq.(16).

$$\begin{cases} K_{11} - K_{12} = K_{21} - K_{22} = 1 \\ K_{13} = K_{23} < a \\ K_{14} = K_{24}, K_{15} = K_{25} < b \\ K_{11} < K_{21} < c \\ K_{31} = K_{32} = K_{33} = K_{34} = K_{35} = 0 \end{cases} \quad (16)$$

Where a, b, c : experimental upper limit determined by actual condition. The fifth equation of the Eq.(16) means that the electric motor torque is set according to feedforward, as shown in Eq.(13). With the constraints defined in Eq.(16), each element of the matrix is selected respectively. Proper K_{11} and K_{21} can compensate delay of I_{def} caused by FCE slow responding feature and cut FCE responding time. But over large K_{11} and K_{21} may cause FCE power setting vibrating in some condition. In practice K_{11} and K_{21} are selected according to the experiment. K_{13} and K_{23} are very important for state feedback controller because they determine the stability and stable level of the control system. By analyzing the step-responding of the powertrain, K_{13} and K_{23} can be selected properly. Selected system step-responding curve are presented in Fig.10. It can be seen that the bigger K_{13} and K_{23} are, the faster converging behavior of U_0 is. But over big K_{13} and K_{23} will cause battery voltage vibrating. As shown in Fig.10, when K_{13} and K_{23} equal 10, converging speed of U_0 is moderate and battery voltage converges to zero simplex. Like K_{13} and K_{23} , $K_{14}, K_{15}, K_{24}, K_{25}$ can be selected by the same way.

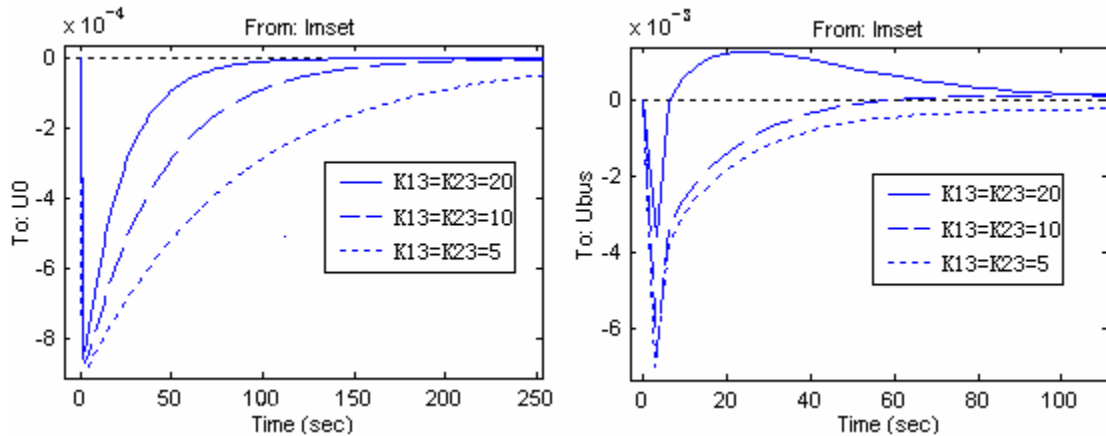

Fig.10 Step-responding curve of the powertrain in difference K_{13} and K_{23}

4. VALIDATION THE POWER CONTROL STRATEGY BY FIELD TEST

Based on the power balance control strategy designed above, the powertrain control strategy is developed consequently and applied in *START3* prototype vehicle. To validate the strategy, simulation and field test are carried out using different cycle, including J1015, UDDS, ECE-EUDC. The result of the simulation and field test shows that the powertrain control system is stable and battery SOC fluctuates between ideal upper limit and lower limit. Selected simulation and test data of UDDS cycle are presented in Fig.11-13.

Example time-trace of the subsystems current in simulation and field test are showed in Fig.12. It can be seen that the fuel cell provides the bulk of the power load while the battery helps with the transient part. Fig.13 shows that battery SOC in UDDS cycle fluctuates between 48% and 52%. The object of powertrain control system is achieved excellently.

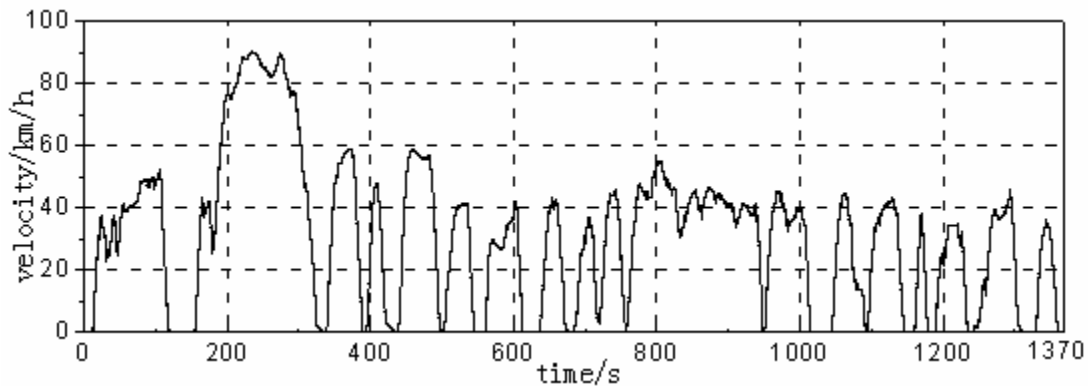

Fig.11 Time-trace of vehicle speed(UDDS cycle)

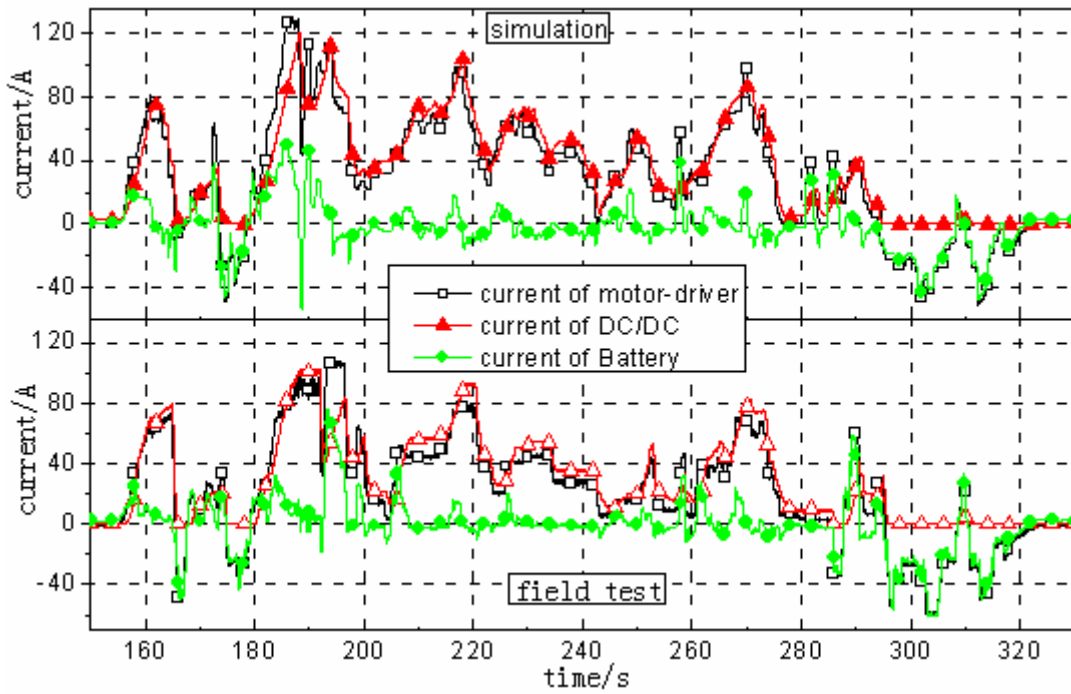

Fig.12 Time-trace of sub-systems current(part of the UDDS cycle)

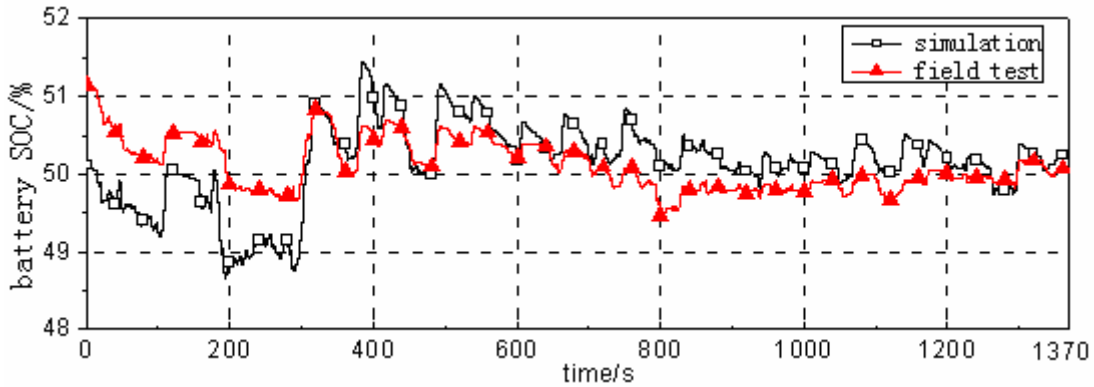

Fig.13 Time-trace of battery SOC (UDDS cycle)

5. CONCLUSIONS

A dynamic state-space mathematic model of FCHV powertrain is developed based on the lab-testing and field vehicle testing result from START3 prototype FCHV. A vehicle simulation model is constructed by following the configuration used in START3. Model validation results confirm that the simulation model is reasonably accurate and the mathematic model is suitable for model-based control strategy development.

Based on the state-space model, a power balance control strategy is developed, which uses full-states feedback algorithm. A Luenberger state observer is designed to estimate the OCV of the battery, which makes state-feedback feasible. The state feedback controller is then designed. Results of simulation and

vehicle field test show that performance of the control system is excellent.

The process described in this paper forms the model-based FCHV powertrain control system development method, which is applied in development of START3 FCHV powertrain control system successfully, and which is the general guidance for powertrain control strategy development for FCHV.

Theoretically full-states-feedback method is advanced, which enhances degree of freedom in control system design, but robustness of the control system is ordinary, and in this paper, index of control system performance is mainly discussed in Frequency Domain. These problems will be discussed in subsequent research project.

ACKNOWLEDGMENT

The authors would like to thank Shanghai Fuel Cell Vehicle Powertrain Company for they helpful support and constructive advices.

REFERENCES

- [1] CHEN Quanshi, QIU bin, XIE Qicheng, et al. Fuel cell vehicle[M]. Beijing: Press of Tsinghua University. 2005
- [2] T.Ishikawa, et al, "Development of next generation Fuel Cell Hybrid System-consideration of high voltage system," SAE paper, No.2004-01-1304
- [3] A. Ohkawa, "Electric Power Control System for a Fuel Cell Vehicle Employing Electric Double-Layer Capacitor," SAE Paper, No.2004-01-1006
- [4] Y. Guezennec, T.-Y. Choi, G. Paganelli, G. Rizzoni , "Supervisory Control of Fuel Cell Vehicles and its Link to Overall System Efficiency and Low-Level Control Requirements," Proceedings of the American Control Conference, Denver, CO. 2003 .
- [5] Mohsen Mohammadian, et al., "Neuro-Genetic Energy Management For Hybrid Fuel Cell Power Train" Proceedings of the 2006 IEEE Conference on Cybernetics and Intelligent Systems. Singapore. 13 December, 2006
- [6] T. Markel, et al., "ADVISOR: a systems analysis tool for advanced vehicle modeling," Journal of Power Sources, Vol. 110, 2002, pp.255-266

- [7] Wei Xuezhe, "Study on Li-ion Power Battery Management System in Fuel Cell Vehicle," Dissertation submitted to Tongji University for degree of Doctor of Engineering, 2005
- [8] M. Hou, P. Ming, D. Sun, et al. "The Characteristics of a PEM Fuel Cell Engine with 40 kW Vehicle Stacks", Fuel Cells, 2004,4.No1-2, page:101-104
- [9] Zhang Chengqian. System Identification and Parameters Estimation. Beijing: China Machine Press, 2001
- [10] Dirf R.C, Modern control system, Science Press, Beijing, 2002
- [11] Zhu Yuan, "The Four-steps Design Method of Energy Management for Hybrid Electric Vehicle," Dissertation submitted to Tshinghua University for degree of Doctor of Engineering, 2003
- [12] Zhong Zaimin, Wei Xuezhe, Sun Zechang, "Research on Control Principle of Fuel Cell Vehicle Powertrain," Journal of Tongji University(Natural Science), 2004, 6, page: 758-761