

Quadrature Phase Shift Keying Modulator & Demodulator for Wireless Modem

¹Tayab D Memon, ²Waliullah Ghanghro, ³Dr. BS Chowdhry, Senior Member IEEE, ⁴Ayaz A Shaikh

tayab.memon@student.rmit.edu.au, enr_waliullah@yahoo.com, c.bhawani@ieee.org, ayaz.shaikh@student.rmit.edu.au

¹PhD Student at RMIT, Melbourne & Lecturer Dept of Electronic & Biomedical Engg MUET, Jamshoro
Cell Phone (Aus): 0061433941613, Office: 0061399255315, Home: 0061380608671

²SR Design Engineer, COMCEPT, Pvt. Ltd, Islamabad,

³Prof. & Chairman Dept of Electronic & Biomedical Engineering,

⁴PhD student at RMIT, Melbourne, & Lecturer Dept of Telecommunication Engineering, MUET, Jamshoro.

Abstract— Digital modulation is a process that impresses a digital symbol on to a signal suitable for transmission on a wired or wireless medium in order to receive that signal at receiving end correctly without any loss of information. Quadrature phase shift keying (QPSK) modulation technique is the most widely used modulation scheme in modern digital communication systems; it provides high performance on bandwidth efficiency and bit error rate. In this paper the complete model of QPSK modulator and demodulator has been developed. The model has been simulated in Matlab Simulink. The results are tested and verified. In final hardware design and implementation has been proposed using MC1496 Balanced Modulator-Demodulator. This design is step forward towards the low cost modulation for mobile communications. Generally QPSK modulation has various applications in mobile communications and particularly in the design of wireless modem, cellular CDMA communication, WiMAX (IEEE 802.16) etc.

*Key Terms—*QPSK, Wireless Modem, QPSK Hardware Implementation, MATLAB Simulation of QPSK.

Quadrature Phase Shift Keying Modulator & Demodulator for Wireless Modem

¹Tayab D Memon, ²Waliullah Ghanghro, ³Dr. BS Chowdhry, ¹Ayaz A shaikh

¹PhD Student at RMIT, Melbourne, Australia & Lecturer Dept of Electronic & Telecom: Engg: MUET.

³Prof. & Chairman Dept of Electronic & Biomedical Engineering, MUET, Jamshoro.

²SR Design Engineer COMCEPT Private Ltd Islamabad, Pakistan.

Abstract— *Digital modulation is a process that impresses a digital symbol on to a signal suitable for transmission on a wired or wireless medium in order to receive that signal at receiving end correctly with out any loss of information. Quadrature phase shift keying (QPSK) modulation technique is the most widely used modulation scheme in modern digital communication systems; it provides high performance on bandwidth efficiency and bit error rate. In this paper the complete model of QPSK modulator and demodulator has been developed. The model has been simulated in Matlab Simulink. The results are tested and verified. In final hardware design and implementation has been proposed using MC1496 Balanced Modulator-Demodulator. This design is step forward towards the low cost modulation for mobile communication. Generally QPSK modulation has various applications in mobile communications and particularly in the design of wireless modem, cellular CDMA communication, WiMAX (IEEE 802.16) etc.*

Index Terms—QPSK, Wireless Modem, QPSK Hardware Implementation, MATLAB Simulation of QPSK.

I. INTRODUCTION

INTERNET has converted this world into global village. Now people want to communicate while on move. Wireless is the technology that makes it possible. In last few years, the mobile radio communication industry has grown exponentially. By the fabrication of high density low power, low noise, small size and reliable digital and RF chips make radio equipment smaller, cheaper and more reliable. Due to this explosive growth of mobile and wireless users there are so many problems created, the most critical problem is frequency spectrum, Bit Error Rate (BER) and Bandwidth. In this paper the Quadrature Phase Shift Keying is addressed as modulation and demodulation scheme for the wireless modem.

II. DIGITAL MODULATION

A. Overview

Digital modulation is a process that impresses a digital symbol on to a signal suitable for transmission on a wired or wireless

medium in order to receive that signal at receiving end correctly with out any loss of information [1].

For short distance transmissions, base band modulation is usually used, which is referred as line coding.

In long distance and wireless transmission, band pass modulation (carrier modulation) is used. In band pass modulation a base band signal is modulated over a high frequency sinusoidal carrier signal. The bandwidth of this modulated signal depends upon the base band signal and modulation scheme to be used. A sequence of digital symbols is used to alter the parameters of high frequency carrier signal like; amplitude, phase and frequency. In this way three basic digital modulation schemes are amplitude shift keying (ASK), frequency shift keying (FSK), and phase shift keying (PSK). Besides on these basic digital modulation schemes a variety of digital modulation schemes can be derived from their combination. For example combination of two orthogonal BPSK modulated signals form quadrature Phase Shift Keying (QPSK). The combination of amplitude modulated signal and phase modulated signal form a quadrature amplitude modulation (QAM). These both modulated techniques i.e. QAM and QPSK are used in IEEE 802.11 (Wi-Fi), IEEE 802.16 (WiMAX) and 3G (WCDMA/HSDPA) Wireless technologies, including Wireless Modem [6]. Another advantage of these techniques is to reduce the bandwidth utilized in PSK or QAM are highly useful [2].

B. Quadrature Phase Shift Keying (QPSK)

QPSK can be stated as a method for transmitting digital information across an analog channel. Data bits are grouped into pairs, and each pair is represented by a particular waveform, called a symbol, to be sent across the channel after modulating the carrier [3].

The most commonly used modulation scheme for wireless and cellular systems is Quadrature Phase Shift Keying (QPSK). It's because it does not suffer from BER degradation while the band width efficiency is increased [1]. The QPSK signals are mathematically defined as [4]:

$$s_i(t) = A \cos(2\pi f_c t + \theta_i) \quad 0 \leq t \leq T, \quad (1)$$

$$\text{Where } \theta_i = \frac{(2i-1)\pi}{4} \quad (2)$$

The carrier frequency is chosen as integer multiple of the symbol rate, therefore in any symbol interval, the signal initial phase is also one of the four phases $(\frac{\pi}{4}, \frac{3\pi}{4}, \frac{5\pi}{4}, \frac{7\pi}{4})$.

The above expression can be written as:

$$s_i(t) = A \cos \theta_i \cos 2\pi f_c t - A \sin \theta_i \sin 2\pi f_c t$$

$$s_i = s_{i1} \phi_1(t) + s_{i2} \phi_2(t) \quad (3)$$

Where

$$\phi_1 = \sqrt{\frac{2}{T}} \cos 2\pi f_c t, \quad 0 \leq t \leq T \quad (4)$$

$$\phi_2 = -\sqrt{\frac{2}{T}} \sin 2\pi f_c t, \quad 0 \leq t \leq T \quad (5)$$

$$s_{i1} = \sqrt{E} \cos \theta_i \quad (6)$$

$$s_{i2} = \sqrt{E} \sin \theta_i \quad (7)$$

$$\theta_i = \tan^{-1} \frac{s_{i2}}{s_{i1}} \quad (8)$$

Therefore the QPSK signal can be entirely written as:

$$S(t) = \frac{A}{\sqrt{2}} [I(t) \cos 2\pi f_c t - Q(t) \sin 2\pi f_c t] \quad -\infty < t < \infty \quad (9)$$

The constellation diagram of QPSK signal is shown in fig.1.

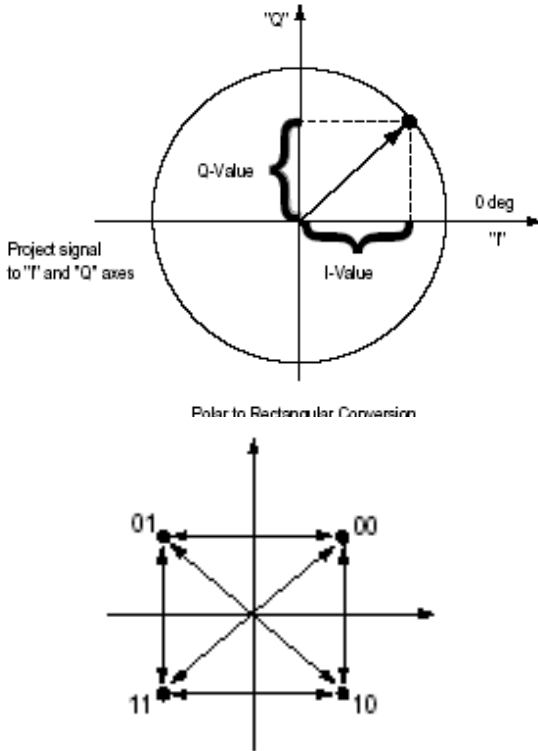

Fig. 1: Constellation diagram of QPSK modulation

III. MODEL BLOCK DIAGRAM

A. QPSK Modulator

QPSK modulator consists of two binary phase shift keying (BPSK) modulators, serial to parallel (S/P) converter shift register, oscillator and 90° phase shifter [5]. The binary serial bit sequence with bit rate R_b applied to modulator is converted into two bit parallel sequence I-bit and Q-bit each of having bit rate $R_b/2$ [8]. These I and Q bits are applied to BPSK modulators, whose carrier frequency is orthogonal to each other. This orthogonal signal is achieved through phase shifter; which shift the applied signal to 90° . The output from both BPSK modulators is added by summing amplifier; which results QPSK modulated signal. The block diagram of QPSK modulator is given in fig.2.

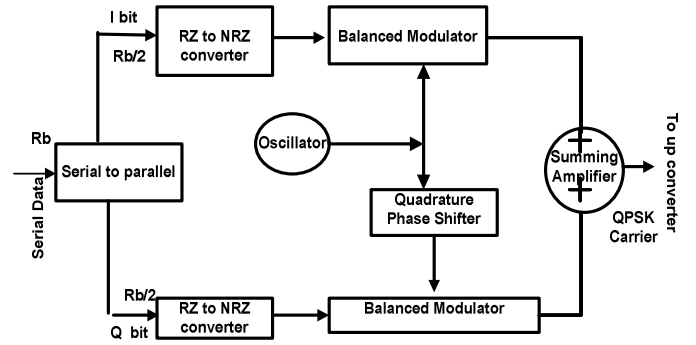

Fig.2. Block Diagram of Quadrature Phase Shift Keying (QPSK) Modulator.

B. QPSK Demodulator

In demodulation the received QPSK modulated signal is fed to two BPSK demodulators. The carrier signal is applied to 1st BPSK demodulator to receive the I bit, and the 90° phase shifted carrier signal is applied to 2nd BPSK demodulator to receive the Q bit. Output from both BPSK demodulators is passed through low pass filter and sampled to get digital I and Q data bits. These I and Q bits are applied to two bit parallel to serial (P/S) shift register to get original data stream that was transmitted from QPSK modulator.

The original transmitted signal can be demodulated correctly by generating the coherent carrier signal. The carrier recovery circuit regenerates the original carrier signal. The carrier recovery circuit is a phase locked loop (PLL) system, consisting of a voltage controlled oscillator (VCO), phase detector and low pass filter. The phase and frequency of VCO depends upon the feedback from the low pass filtered phase detector.

The block diagram of QPSK demodulator is given in fig.3.

IV. SOFTWARE IMPLEMENTATION

A. QPSK Modulator

The QPSK modulator model is simulated in Matlab, Simulink. The simulated model is given in fig. 4 and the resulting wave

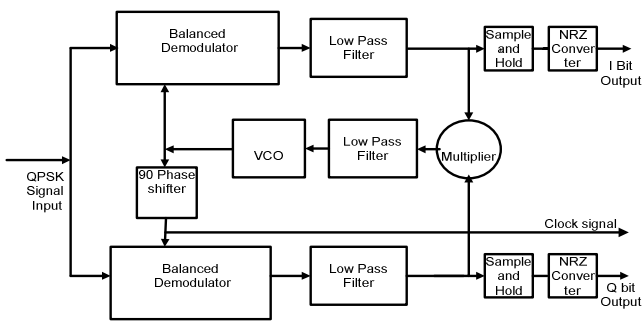

Fig. 3. QPSK Demodulator. The input is QPSK signal & output is I-Bit & Q-Bit.

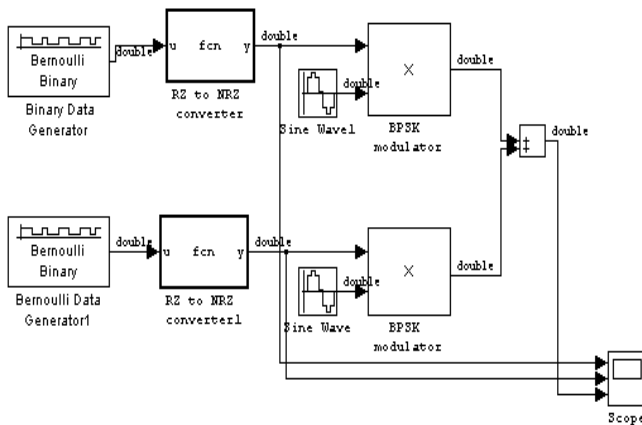

Fig.4. QPSK Matlab Modulator Model.

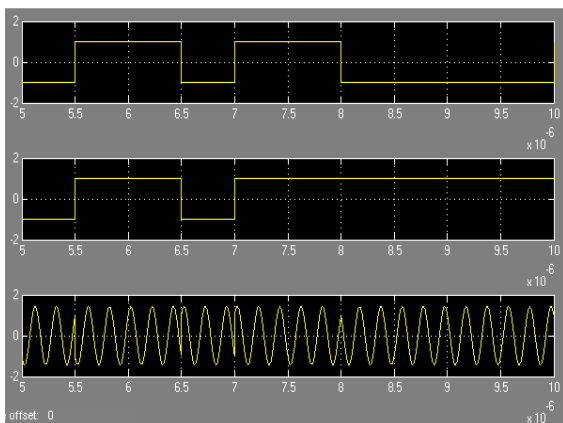

Fig. 5. Modulation Results

The Matlab Simulink demodulation model of QPSK is given in fig.6. The simulation results of Matlab model are given in fig.7. While QPSK signal is passed from multiplier, its carrier frequency component is suppressed, it resembles to digital bits. It has still high frequency components. At the out put of Bessel filter signal is smooth sequence of -1 to +1. After passing it from RZ to NRZ block is it the sequence of 1 and 0 digital signal.

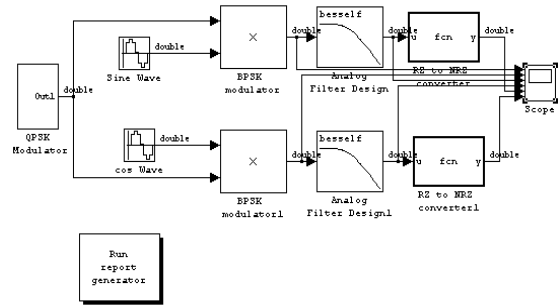

Fig.6. QPSK Demodulation in Matlab

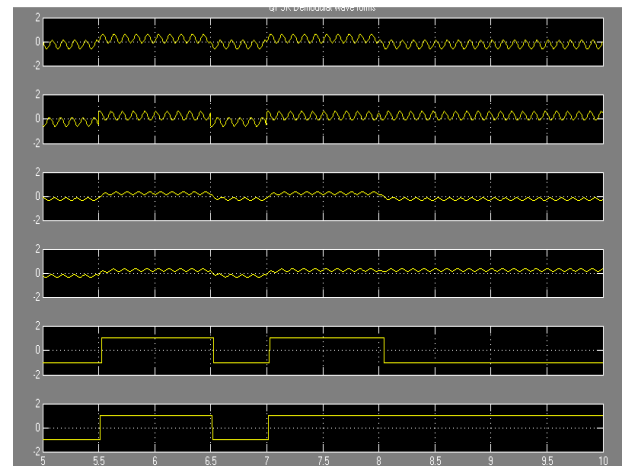

Fig.7. QPSK Demodulation Matlab Results

V. HARDWARE IMPLEMENTATION: QPSK MODULATOR

A. Proposed Balanced Modulator

The MC1496 IC [7] is used as a balanced modulator; because it makes an excellent building block for high frequency communications equipment. The device functions as a broadband; double-sideband suppressed carrier balanced modulator without a requirement for transformers or tuned circuits. In addition to its basic application as a balanced modulator/demodulator, the device offers excellent performance as an SSB product detector, AM modulator/detector, FM detector, mixer, frequency doublers, phase detector, and more. The schematic of MC1496 is shown in fig. 8.

The operation of the MC1496 consists of applying a high level input signal to the dual differential amplifiers, Q1, Q2, Q3, and Q4, (carrier input port) and a low level input signal to the lower differential amplifier, Q5 and Q6, (modulating signal input port) [7]. This results in saturated switching operation of carrier dual differential amplifiers, and linear operation of the modulating differential amplifier. The resulting output signal contains only the sum and difference frequency components and amplitude information of the modulating signal. This is the desired condition for our applications. The schematic diagram of balanced modulator is shown in fig. 9.

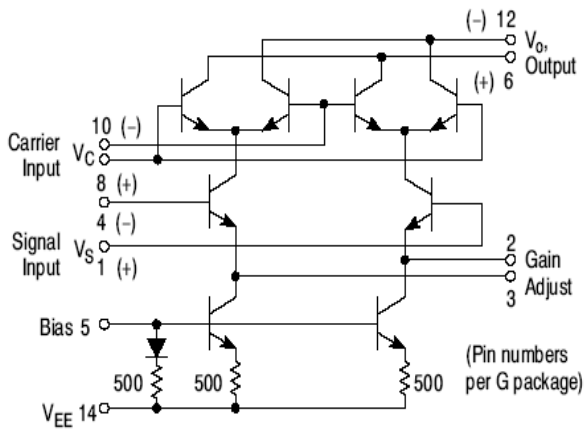

Fig.8. Schematic of Balanced Modulator

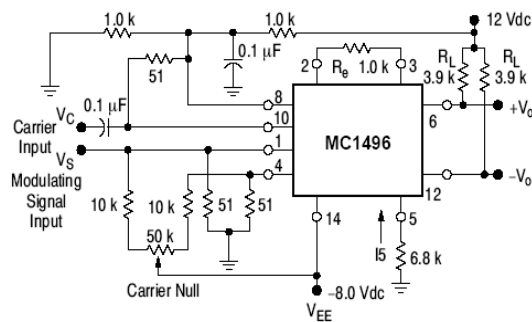

Fig.9. Balanced Modulator typical Circuit.

The quadrature phase shifter is designed by differential circuit. As the carrier is a sinusoidal signal, and derivative of sin is cos; which is 90° out of phase with sin wave. The circuit diagram of phase shifter is given in fig.10 and its results are shown in fig. 11. The values of circuit components are for the 10 MHz carrier frequency.

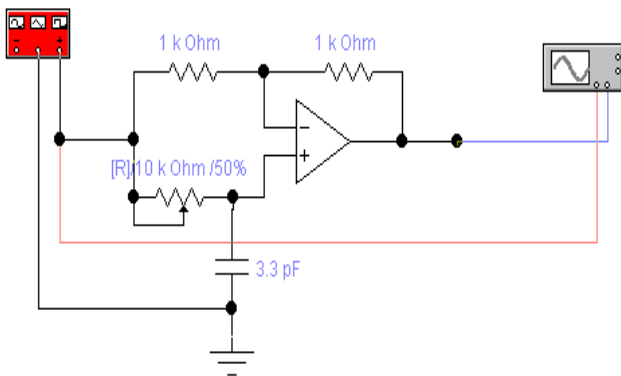

Fig.10. Phase Shifter Diagram

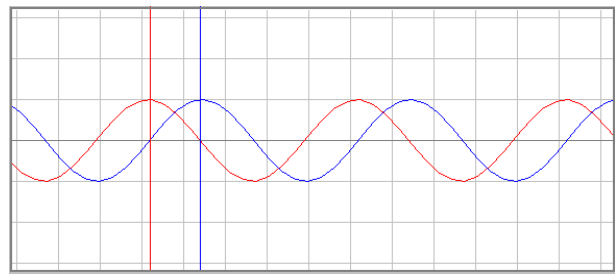

Fig.11.Phase Shifter Output.

C. Summing amplifier

The I-bit modulated signal from BPSK-1 modulator is applied to the I-input of summing amplifier and the Q-bit modulated signal from BPSK-2 modulator is applied to the Q-input of summing amplifier where these are linearly added to generate of

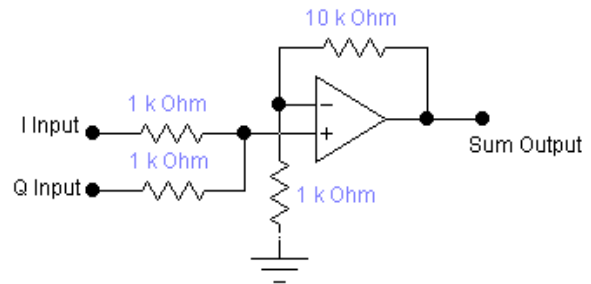

Fig. 12. Summing Amplifier

D. RZ (Return to Zero) to NRZ (Non-Return-to-Zero) converter

The digital signal applied to BPSK modulator is non-return-to-zero coded, but signal from serial to parallel shift register is return to zero. The circuit shown in fig.13 is used to convert RZ coding to NRZ coded signal.

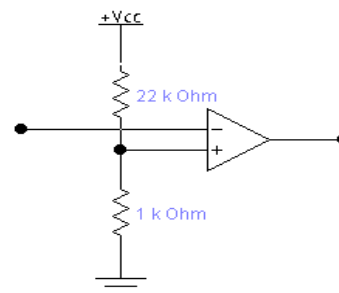

Fig. 13. Return to Zero (RZ) to Non-Return-to-Zero (NRZ)

E. Carrier signal generator

The carrier frequency is generated using a crystal oscillator, to get stable phase response as desired in communication systems. The oscillator is designed around a BJT transistor. It operates at 10 MHz frequency. The output of oscillator is applied to balance modulator BPSK1 and phase shifter. The schematic is shown in fig 14.

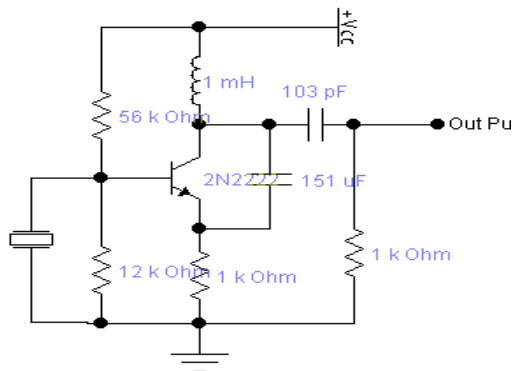

Fig. 14. Carrier Signal Generator

F. Serial to parallel Converter

Data sent to QPSK modulator is a sequence to serial bits; which is converted to two bit parallel sequence called I and Q bits. The schematic diagram of serial to parallel converter is shown in fig. 15.

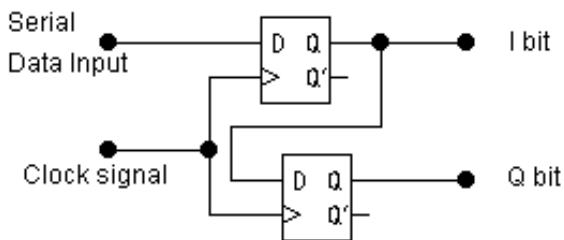

Fig.15. Serial to Parallel Conversion

VI. HARDWARE IMPLEMENTATION OF QPSK DEMODULATOR

A. Proposed Demodulator

In demodulation section the most of the circuit parts are same; that described in modulator section; which are balanced modulator/Demodulator, low pass filter, phase shifter and NRZ converter. Only the new components are VCO, P/S converter and sample and hold circuit.

B. Voltage controlled oscillator (VCO)

In the design of VCO two requirements must be fulfilled in order to obtain oscillation in the closed loop circuit:

1. The closed loop gain must be greater than or equal to one.
2. The phase shift around the loop is $N \cdot 360^\circ$, where N is an integer.

VCO can have the output frequency change with a change in voltage at a control pin of the oscillator. The amount of frequency shift with a given voltage change is highly dependent on the oscillator circuit. Commonly 35% to 50% frequency variation per volt can be achieved and for higher ranges we need to add an inductor in VCO circuit with crystal. Most VCOs use varactor diodes to vary the frequency. The varactor diode changes the capacitance across its terminals based on the DC (or low frequency AC) voltage across the

same terminals. A common transistor circuit for VCO is shown in fig 16.

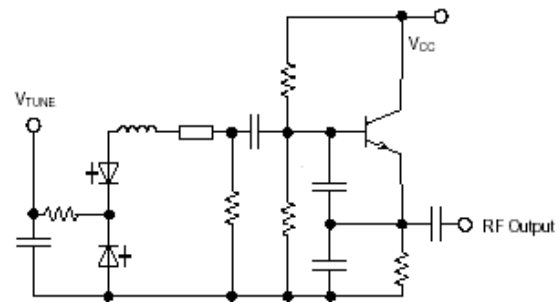

Fig. 16. Voltage Controlled Oscillator

C. Sample and Hold Circuit

Signal from BPSK demodulators is applied to the input of sample and hold circuit; which takes the sample of signal at proper interval determined by clock signal and holds that signal information till next sample.

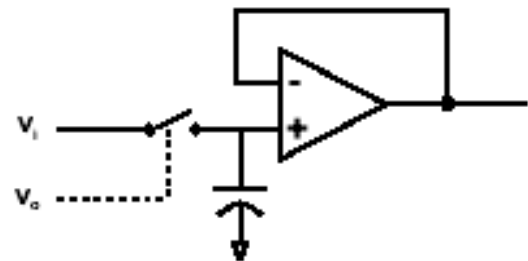

Fig.17. Sample & Hold Circuit

The holding time depends upon the capacitor value used in the circuit. And sampling time depends upon the clock signal applied to V_s pin. The schematic circuit diagram of sample and hold circuit in shown in fig. 17.

VII. CONCLUSION

In this paper at first stage the digital modulation has been reviewed followed by Quadrature Phase Shift Modulation (QPSK). In second stage the QPSK Modulator & Demodulator block diagrams are discussed. In third stage the QPSK modulator & demodulator are simulated in Matlab Simulink. The results of both modulator & de-modulator are given. In final stage the complete hardware implementation of QPSK Modulator-Demodulator using MC1496 has been proposed.

VIII. REFERENCES

- [1] DANIEL SANTANA GÓMEZ, I. A. AGUIRRE-HERNÁNDEZ, Y. L. RODRÍGUEZ-GUARNEROS, JAVIER EDUARDO GONZÁLEZ VILLARRUEL "PSK Digital Modulation DSP Implementation Applied To software Radio", in Proceedings of the Electronic, Robotics and Automotive Mechanics Conference (CERMA'06) , IEEE Computer Society.
- [2] Rakesh Sambaraju, OSA, Miguel Ángel Piqueras, Valentín Polo, Juan L. Corral, and Javier Martí, " Generation of Multi-GigaBit Per Second

MQAM/MPSK-Modulated Millimeter Wave Carriers Employing Photonic Vector Modulator Techniques” , in journal of light wave technology, vol.25, No. 11, November, 2007.

- [3] Douglas L. Jones, Swaroop Appadwedula, Matthew Berry, Mark Haun, Jake Janovetz, Michael Kramer, Dima Moussa, Daniel Sachs, Brian Wade, “Digital Transmitter: Introduction to Quadrature Phase-Shift Keying”, in Connexions module: m10042, Version 2.19: Feb 25, 2004 11:59 am US/Central.
- [4] “All About Modulation”, Copyright 2002 Charan Langton, revised Dec 2005, WWW.COMPLEXTOREAL.COM
- [5] Abhishek Mitra, “All-Digital Quadrature Modem for High Speed Wireless Communications”, Project at IIT Allahabad, from 27th Jan2003-22nd May 2003.
- [6] SAM W. HO, “Adaptive Modulation (QPSK, QAM)”, Intel in Communication, copyright 2004, Intel Corporation.
- [7] Data Sheet of MC1496 available online at : <http://web.telia.com/~u85943828/misc/1496.pdf>
- [8] Cecil Deisch “Low-Power Approach Provides QPSK Modulation”, in Microwaves & RF, May, 2006. Online Available: [HTTP://WWW.MWRF.COM/ARTICLES](http://WWW.MWRF.COM/ARTICLES)



Tayab Din Memon has been working at SECE, RMIT as International PhD student. He received his B.E and PgD in Electronics Engineering from Mehran University of Engineering & Technology, Jamshoro, Sindh, Pakistan in 2004 and 2006. He joined for six month the Chemi Visco Fiber Ltd as “Trainee Instrumentation & DCS Engineering”. From Sep 2004 to June 2008 he worked at MUET as Lecturer Electronic Engineering. He lectured on various

undergraduate subjects. He joined SECE, RMIT as International RMIT student in 2 Semester 2008. His research interests are FPGAs, Embedded Systems, and Digital Signal Processing. His PhD project is “Short Word Length DSP System for Mobile Communication”. His research goal is to develop a cost effective adaptive filter for audio processing in cellular communication. Its implementation would be done by using FPGA Platform. It would reduce the size of the present audio processing circuit & are expected to get better results comparatively. In addition 5 technical [international/national] papers are on his credit. He is also co-author of book titled “Digital Electronics & Microprocessor Technology”, published by Naseem Book Depot, Foudari Road, Hyderabad.